



**“WHY LEADERS WIN PRICE WARS”**

Part of being a leader is being able to withstand the arrows of price competition. A leader need not be the biggest or the oldest company in its field, but it's the one that stands out because it is recognized as the best. It wins price wars because its reputation for excellence in its field will not be obliterated by price-cutting.

A leader is also usually a living – and very healthy – testimonial to the effectiveness of an important marketing principle: **That in the long run it profits you far more to sell your product on its value rather than its price.**

Almost everyone will agree with that principle in theory; but many violate it in practice. It is often so easy to pick up quick sales by promoting “special prices” or “deals”. And it is so hard to resist the temptation to fight the fire with fire when price-cutting competitors are apparently hurting you.

But when you get down and fight the “cut-price” merchandiser on his home grounds, and by his rules, you place yourself in danger of losing much and gaining little. You identify your fine product with his and destroy, in the minds of customers, some of your product's distinctive value. You may gain short-term sales, but you are apt to sacrifice the kind of customer respect, which creates long term growth.

Perhaps the main reason more manufacturers do not sell on value rather than on price is that selling on value is far more difficult than selling on price. It requires, of course, a product that has value. But that is only the beginning.

It also requires the marketing wisdom to know what specific “character” you should create for your product to separate it most favorably from all others of its kind. Then it requires the creative skill to crystallize that character on paper or on the air, and project it into the minds of the right people at the right time!

It requires something else, too – the lonely courage to stand out from the crowd, to tell your own story consistently, year in and year out, regardless of the opportunistic tactics of competition. Perhaps, this courage is the rarest quality of all. This quality is sometimes called Leadership.

Many companies in various industries, the leaders in their fields, believe as strongly as we do that if they market products on the basis of value, rather than on the basis of price, it will pay off – in greater long-term profits and more solid growth.

Courtesy of Masteller

**REMINC STAFF**

- Art Bancroft - Chairman / CEO
- Ralph Barton - President
- Laurie Mandly - Executive Vice President
- Ken Gomes - Vice President
- John Reynolds - Project Manager
- Bill Teixeira - Project Engineer
- Suzanne Lilly - Special Projects Engineer
- Beth Rondeau - Director of Financial Admin.
- Muriel Boyd - Executive Secretary

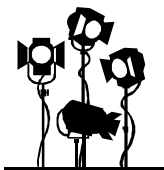

**SPOTLIGHT ON**  
**Carl-Gösta Dock**



Since his retirement in 1988, Carl has provided our sister company CONTI with technical & marketing assistance in the Swedish marketplace. Having over 40 years of service in the fastener field, Carl worked mostly within the product, research, & education areas of fasteners. He has also served as President for the ISO fastener committees of TC-1 & TC-2. Carl was the originator of the “In-Place Cost” or IPC concept, which centers on the engineering of fasteners into end-user applications to lower the in-place cost of assembly for the fastener system.

R E G I S T E R



## PRESIDENT'S PERSPECTIVE

### "AVOIDING PATENTED FASTENERS?"

We frequently encounter individuals or companies that on principle refrain from using patented fasteners or putting trademarks on drawings or specifications, as they have the belief that the patented product price will always be higher than that of a generic version, if such alternative is available. In my view, applying this practice without careful case-by-case analysis can actually be costly for the company that adopts it.

A patented fastener can be more expensive, but most frequently, the added cost is justified because the product has one or more demonstrable advantages. Typically these advantages give better performance and provide greater cost-savings than would the generic alternative.

Another advantage of a patented fastener is that, being produced under license, its quality will be uniform, guaranteeing consistent performance and it typically can be procured globally, made to the same high standards.

Additionally, a patented fastener is normally sold under a registered trademark. The trademark defines a specific product, so you can be sure the fastener being purchased is precisely the type you require and will function in accordance with your expectations. Alternatively, buying a generic version of a patented fastener provides no assurance that its quality and performance will be either acceptable or consistent, especially when purchased from different sources.

In addition, patented products are generally offered by reputable companies. By sourcing from such suppliers, you can take advantage of their product warranty and technical support, should you encounter any application problems.

The saying, "You get what you pay for" usually has merit. Determine exactly which fastener you require, specify it by trademark, and then you can be assured satisfaction. We preach this doctrine because our experience indicates that buying inexpensive generic fasteners often increases the total cost of assembly, all factors considered. Should you have an aversion to using patented fasteners, think again, as this policy may be unfounded and could be costing you money!



### WEBSITE

REMINC has an excellent source for information on TRILOBULAR™ products – the REMINC Website! We are continually upgrading the website with new and useful information. Recently, we have added all of our catalogs and newsletters in .pdf format.

The web site contains product descriptions, our contact information, detailed contact listings for all of our global authorized manufacturers, many application and cost savings examples and a frequently asked questions section.

Please be sure to make full use of the REMINC Web Site at: [www.taptite.net](http://www.taptite.net) or [www.taptite.com](http://www.taptite.com).



Originators of the TAPTITE®  
TRILOBULAR™ Family of Fasteners

Providing Technical & Marketing Support  
and Innovative Fastener Design

Please click on your location on the map to



continue:

\*TAPTITE® PRODUCTS ARE PRODUCED BY 66 MANUFACTURERS WORLDWIDE\*

The following are trademarks licensed by REMINC:  
TRILOBULAR™, TAPTITE®, DUO-TAPTITE®, CORFLEX®, PLASTITE®, POWERLOK®, TAPTITE 2000®,  
TAPTITE® CA, EXTRUDE-TITE®, KLEERLOK®, KLEERTITE®, REMFORM®, TRUSTART®  
Site Design by RIZ

# PROPER ASSEMBLY "STACK-UP"

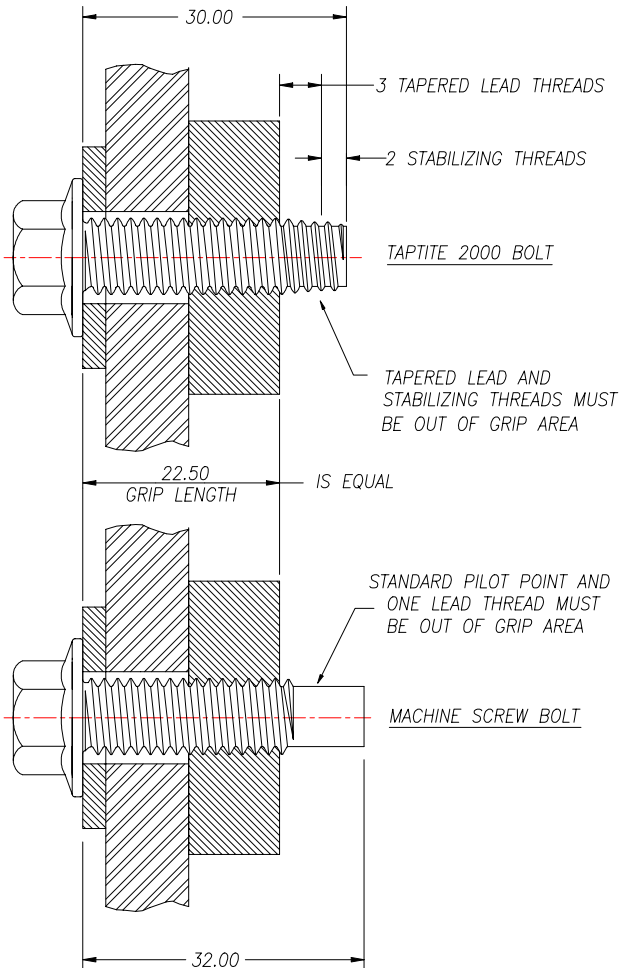

TYPICAL STACK-UP EXAMPLE

Figure 1

When designing a nut and bolt joint, the length of the bolt is determined by the aggregate thickness of the components (laminates) being assembled. This thickness is often referred to as the "stack-up" of the joint being designed. The total thickness of the components and the nut thickness determine the grip length requirement of the bolt. *Additional bolt length* must be allotted for the length of any under-filled or tapered point threads and "dog" or pilot point, if specified.

To determine the proper length of a TAPTITE 2000® bolt, the same procedure is followed. However, the stabilizing and tapered thread-forming threads, which are five pitches long, must be added to the grip length to establish the overall bolt length.

The standard TAPTITE 2000® bolt *does not require* a "dog" or pilot point. The stabilizing threads are sized closer to the pilot hole diameter than would be possible with a pilot point. A TAPTITE 2000® bolt stands up straight in the pilot hole and requires very little end-load to initiate thread-forming, which is extremely beneficial in automated assemblies.

Figure 1 shows a typical comparison of a M10 pilot-pointed machine screw bolt and a M10 TAPTITE 2000® bolt. The TAPTITE 2000® bolt fits into a pilot hole better than an unthreaded pilot point bolt, and often results in a shorter overall length, while maintaining the same grip length as the machine bolt.

Thus, the TAPTITE 2000® bolt's tapered lead and stabilizing threads not only perform the "aligning" function of a pilot point, but improve the stability of the fastener in the hole. These unique features have allowed companies to eliminate the "hand-starting" of fasteners on automated assembly lines.



## REMINC Responds!

### FIELDING THE QUESTIONS

- Q. What is the difference between a "standard" TAPTITE 2000® fastener and the new TAPTITE 2000® "SP"™ fastener?
- A. The "SP" stands for "short point". For TAPTITE 2000® products, the "SP" version does not have the stabilizing threads. Thus, the point of the bolt on any diameter of the "SP" version has only 2½ lead-in threads versus the 3 lead-in threads and 2 stabilizing threads on the "standard" version for sizes M6 and larger and 2½ lead-in threads on sizes M5 and smaller.
- Q. When should I use TAPTITE 2000® "SP"™ fasteners?
- A. The "SP" version was specifically developed for use in soft metal (aluminum and zinc alloys) die-castings, where the depth of the blind pilot hole can have limited length. "SP" products also have been used for special applications in steel with extreme joint length restrictions. Thus, in order to take advantage of all of the "standard" TAPTITE 2000® fastener benefits, we recommend the use of "SP" products in steel only on very unusual and length restrictive applications.

REMINC Training / Brochure Request Form

Please Check:

Name: \_\_\_\_\_

Company: \_\_\_\_\_

Address: \_\_\_\_\_  
\_\_\_\_\_

Telephone: \_\_\_\_\_

Fax: \_\_\_\_\_

E-mail: \_\_\_\_\_

- Contact me regarding a training visit
- REMINC General Products Catalog
- TAPTITE 2000® Products Application Guide
- TAPTITE 2000® Product Brochure
- REMFORM® Product Brochure
- TRU-START® Product Brochure
- FASTITE® 2000™ Product Brochure
- "54 Ways TAPTITE 2000® Fasteners Lower the Cost of Assembly" Request Form

Mail this form to REMINC at 25 Enterprise Center, Middletown, RI 02842 USA or fax it to fax #: (401) 841-5008

The following are patented products and/or trademarks licensed by REMINC:  
TAPTITE®, TAPTITE ®, TYPE-TT®, DUO-TAPTITE®, CORFLEX®, PLASTITE®, POWERLOK®, TRILOBULAR™,  
KLEERTITE®, REMFORM®, THE CONTROLLABLE PRODUCT®, ENGINEERED FASTENINGS®,  
EXTRUDE-TITE®, KLEERLOK®, TAPTITE 2000®, TAPTITE 2K®, TYPE TT 2000®, TYPE TT 2K®, TAPTITE 2000 & DESIGN®

COPYRIGHT 2003, RESEARCH ENGINEERING & MANUFACTURING INC.  
ALL RIGHTS RESERVED

No part or contents of this newsletter may be reproduced without the expressed written consent of  
Research Engineering & Manufacturing Inc.



Research Engineering &  
Manufacturing Inc.  
25 Enterprise Center  
Middletown, RI 02842, U.S.A.  
Tel: (401) 841-8880  
Fax: (401) 841-5008  
Web site: [www.reminc.net](http://www.reminc.net)  
E-mail: [reminc@reminc.net](mailto:reminc@reminc.net)

1958 - 2003  
Celebrating 45 Years  
Lowering the Cost of  
Assembly

